

D4 Series

DOUBLE SEAT MIX PROOF VALVES



SPX FLOW is a leading innovator of process solutions with decades of experience in valve design covering premium brands such as APV™ and Waukesha Cherry-Burrell™. From the supply of engineered components to complete process engineering and design, we specialize in helping our customers improve their plant's performance and profitability.

Based on more than 60 years experience in valve design and manufacturing, SPX FLOW has developed the D4 series hygienic double seat mix proof valve to fulfill the demands of today's process industry. Installing the D4 Series valves is an investment in efficiency, production flexibility, and uptime. When designing this valve, great emphasis has been put on facilitating return on investment, safety, and maintenance.

SPX FLOW, Inc. (NYSE:FLOW) is a leading manufacturer of innovative flow technologies, many of which help define the industry standard in the market segments they serve. From its headquarters in Charlotte, North Carolina, it operates a sales and support network, centers of manufacturing excellence, and advanced engineering facilities, throughout the world. Its cutting-edge flow components and process equipment portfolio includes a wide range of pumps, valves, heat exchangers, mixers, homogenizers, separators, filters, UHT, and drying technology that meet many application needs. Its expert engineering capability also makes it a premium supplier of customized solutions and complete, turn-key packages to meet the most exacting of installation demands.

Incorporating many leading brands, SPX FLOW has a long history of serving the food and beverage, power and energy, and industrial market sectors. Its designs and engineered solutions help customers drive efficiency and productivity, increase quality and reliability, and meet the latest regulatory demands. In-depth understanding of applications and processes, state-of-the-art Innovation Centers, and advanced pilot/testing technology further assist in optimizing processes and reducing timescales to reliably meet production targets.

To learn more about SPX FLOW capabilities, its latest technology innovations and complete service offerings, please visit www.spxflow.com.

D4 Series Double Seat Mix Proof Valves

The next generation of mix proof valve technology is the result of continued development from both APV™ and Waukesha Cherry-Burrell™ process technologies. Used for the reliable separation of dissimilar fluids, the D4 Series helps fulfill today's customer demands for production flexibility, increased productivity, rapid return on investment (ROI), and improved product quality across the Food & Beverage, Dairy, Personal Care and Brewing process industries.

D4 Series model range includes:

- D4 – primary, price-competitive model which meets basic mix proof needs for reliable separation, seat lift (SL) or non-seat lift (NSL) cleanability, and low product switching losses
- DA4 – ultra-hygienic model for critical applications requiring enhanced cleanability of product contact surfaces and low CIP losses to drain

FEATURES AND BENEFITS

High value, Low life cycle costs:

- Tiered model range helps to increase ROI and align with customer budgets
- "All In" standard features provide exceptional value
- Reduced inventory costs with same seal kit used on multiple size ranges such as one kit for 1.5" - 3.0" sizes
- Reduced CIP losses improve cost savings
- Low air consumption and air supply requirements
- Long housing ports ease manifold building
- Integrated shaft seal flush reduces need for external piping
- Replacement insert available to easily upgrade existing installations

Reliable performance:

- Fully balanced design helps to prevent hydraulic blocking, withstand pressure spikes, and enables flexible flow direction without slamming
- Light overall weight helps support handling without lifting tools
- Slim stainless actuator is fully enclosed to prevent fluid ingress
- Range of control units and bus communication for automated operation
- No compressed air needed for removal and servicing

Cleanability:

- Designed to the latest hygienic standards
- Standard cavity spray cleaning
- Extensive cleaning of product contact seals



TECHNICAL DATA

TECHNICAL DATA	
SIZES	OD Tube 1.5" - 4" others on request
HOUSING TYPES	41, 42, 43, 44
PRODUCT-WETTED PARTS	1.4404/AISI 316L Other stainless steel parts 1.4301/AISI 304
SEAL MATERIALS	EPDM, FPM, HNBR All seals comply with the FDA requirement
SURFACES	Inside: Ra 32 µ-in (0.8 µm) with Electro-polish Outside: Glass -blasted, satin finish
PRODUCT PRESSURE	145 psi (10 bar)
MAX. TEMPERATURE	EPDM & HNBR: 275°F / 135°C (short time) 284°F / 140°C FPM 275°F / 135°C (not to be used for steam)
STERILIZATION TEMPERATURE	EPDM & HNBR: (short time) 284°F / 140°C
REQUIRED AIR PRESSURE	73 psi (5 bar), valve normally closed

THEORY OF OPERATION:

Double seat mix proof valves are used to efficiently process two different fluids (typically product and CIP) through the valve simultaneously. The mix proof design has two seats which isolate the upper and lower pipe lines when the valve is in the fail-safe closed position. The atmospheric vent cavity in between the seats creates a path for any leakage should the seals fail as well as a drain for CIP solution during seat cleaning. An external CIP spray flush is included to provide enhanced cleaning of the leakage and vent cavity while the valve is closed or open during production.

Valve Closed

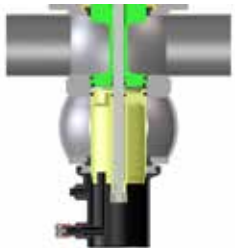

Optional Lower Seat Clean

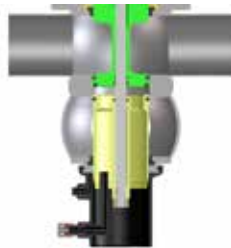

Valve Open

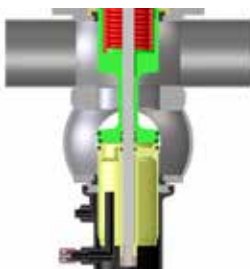

Optional Upper Seat Clean

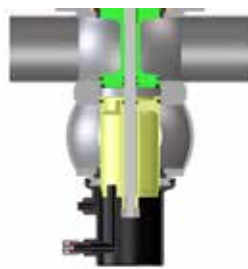

Typical product applications

Food and Beverage

Soups & Sauces
Flavourings & Ingredients
Dressings, Vinegars
Soft/Fruit & Vegetable Drinks
Brewery, Wort, Wine
Pet Food
Fats & Oils, Animal Oils
Liquid Sugar
Cereals



Personal Care and Pharmaceutical

Fluid Medicines
Extracts
Face Creams & Lotions
Perfumes
Soaps
High Purity Water
Nutritional Supplements
Hair Styling Gels & Liquids
Dyes & Alcohols



Chemical

Solvents, Paints
Adhesives
Coatings
Oils & Lubricants
Detergents
Emulsions
Fuels



HOUSING COMBINATIONS

Shut-Off Valves



41(16)



41(17)



41(18)



42



43



44

CONTROL UNITS

CU4 Series



FEATURES AND BENEFITS

- Automated control and position monitoring for reliable processing
- Reduces compressed air and electrical connections
- Helps reduce external solenoid valve cabinets
- Accelerates valve response time
- Reliability and long service life - robust clamp connection, reinforced stainless steel air coupling threads to avoid air leakages, and water tight seals
- Ease of operation - contains manual override solenoids and adjustment screw to throttle air flow to actuator to ensure optimal opening and closing
- Clarity - clear and bright indication of valve position - 5 diodes in LED panel and convenient location
- Standardization - same control top used on various SPX FLOW valve lines, offers common look and controls interface
- NEMA 6 (IP67) washdown rating

CONNECTOR OPTIONS

- S/O Cord Grip for hard wire (standard)
- M12 4-pin connector (optional)

INTERFACE OPTIONS

- 24V DC Direct Connect
- AS-i Field Bus Card

POSITION INDICATION

- 2 internal feedback sensors for valve open/valve closed position detection

SOLENOID VALVES

- 24V DC
- Select 1 (non seat lift) or 3 Solenoids (seat lift)

PRODUCT DIMENSIONS

D4

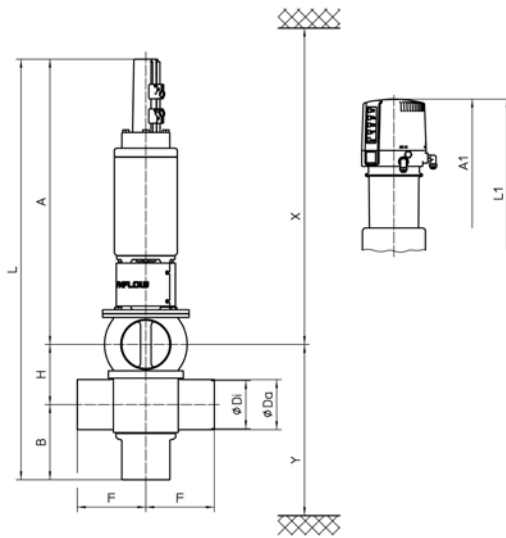

D4SL and DA4

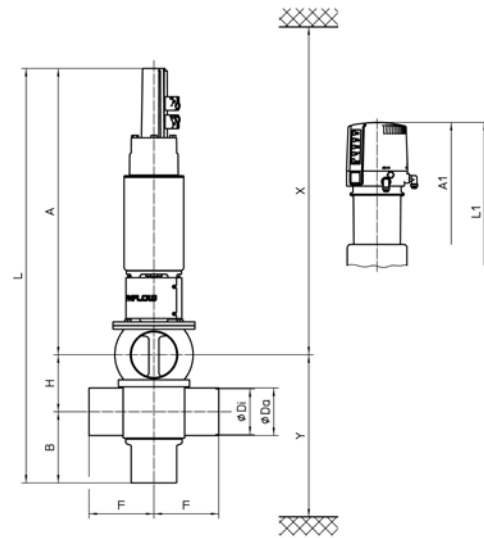

DIMENSIONS IN		A	A1	B	ØDi	ØDa	F	H	L	L1	X*	Y*
INCH												
D4	1.5	19.1	22.4	4.7	1.4	1.5	4.9	2.5	26.3	29.5	32.3	7.8
	2.0	19.2	22.5	4.9	1.9	2.0	4.9	3.0	27.1	30.4	32.7	8.5
	2.5	19.4	22.6	5.2	2.4	2.5	4.9	3.4	27.9	31.2	33.1	9.2
	3.0	19.6	22.9	5.4	2.9	3.0	4.9	3.9	28.9	32.1	33.5	9.9
D4 SL	1.5	20.7	24.0	4.7	1.4	1.5	4.9	2.5	27.9	31.1	34.3	7.8
	2.0	20.8	24.1	4.9	1.9	2.0	4.9	3.0	28.7	32.0	34.6	8.5
	2.5	21.0	24.3	5.2	2.4	2.5	4.9	3.4	29.5	32.8	35.0	9.2
	3.0	21.3	24.5	5.4	2.9	3.0	4.9	3.9	30.5	33.8	35.4	9.9
DA4	1.5	23.1	26.4	4.7	1.4	1.5	4.9	2.5	30.3	33.6	36.6	7.8
	2.0	23.4	26.7	4.9	1.9	2.0	4.9	3.0	31.3	34.5	37.0	8.5
	2.5	23.5	26.8	5.2	2.4	2.5	4.9	3.4	32.1	35.3	37.4	9.2
	3.0	23.8	27.0	5.4	2.9	3.0	4.9	3.9	33.0	36.3	37.8	9.9
	4.0	27.1	30.4	6.1	3.8	4.0	5.6	4.9	38.1	41.4	41.3	11.9

*Minimum installation and valve insert removal dimensions

NOTE: Add the following approximate dimension to "F" for each clamp port connection 0.5" for valve sizes 1.5" - 3.0", 0.62" for valve size 4".

Engineered for Performance and Cleanability

D4 NSL and SL

DA4 Ultra-Hygienic Model

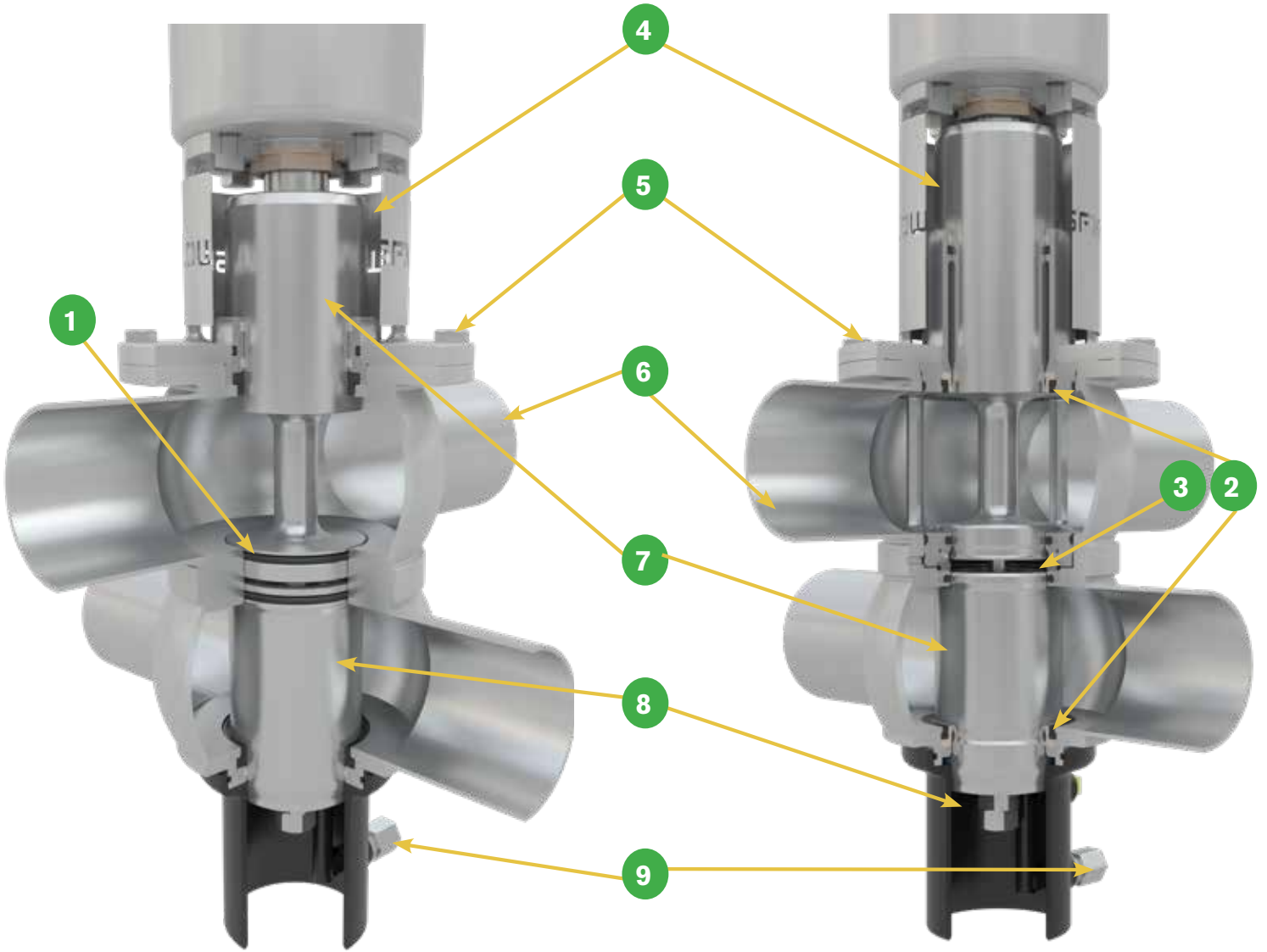

		FEATURE	BENEFIT
D4	1	Radial seal design for reduced losses of product fluids during switching	<ul style="list-style-type: none"> Product cost savings Cleaner operating environment
		Choice of seat lifting (SL) or non seat lifting (NSL) actuator	Modular design to fit a wide range of cleanability and functionality needs
DA4	2	Integrated upper and lower shaft seal and balancer flushing	<ul style="list-style-type: none"> Extensive cleaning of product contact surfaces Helps to reduce external flush piping
	3	Metal orifices control CIP flow during seat lift	Reduces chemical and water loss consumption
		Replacement insert fits into existing DA3+ housing	Easy upgrade to next generation with improved features
D4 and DA4	4	Open yoke design	<ul style="list-style-type: none"> Reduces heat transfer from product zone into actuator Provides visual leak detection of damaged shaft seals Safety guard provided to reduce pinch points
	5	Bolted flange connection for housing/insert	<ul style="list-style-type: none"> Heavy duty, secure connection Reliable and controlled assembly and disassembly of valve insert
	6	Long ports to ease manifold building	Helps to reduce spool pieces and welds to ease manifold building
		Only two seal kit sizes used on entire range: 1.5"-3.0" and 4.0"	Reduces inventory and maintenance costs
		Integrated position sensors	No external wires exposed to washdown and mishandling
		No compressed air required for service	Easy and efficient maintenance
	7	Balanced upper and lower shafts (as standard)	<ul style="list-style-type: none"> No hydraulic blocking; Resistant against pressure spikes Flexibility in either flow direction through the valve (top-to-bottom or bottom-to-top) without water hammering
		Reduced cleaning fluid losses to drain	<ul style="list-style-type: none"> Chemical and water cost savings Cleaner environment due to less chemicals and fluids spilling to the floor
	8	Large separation cavity drain port	Less product risk and guards against pressure build up which could cause cross-contamination.
	9	Flush cavity spray fixed connection (as standard)	<ul style="list-style-type: none"> Enhanced cleaning Removes residual media in separation cavity when full CIP is not readily available Hard-piped flush can be used without need to be removed during valve maintenance
	Light overall weight	Easier handling for maintenance	

D4 Series Double Seat Mix Proof Valves

SPXFLOW



Assembled and tested in Delavan, WI USA

Based in Charlotte, North Carolina, SPX FLOW, Inc. (NYSE: FLOW) is a multi-industry manufacturing leader. For more information, please visit www.spxflow.com

SPX FLOW

611 Sugar Creek Road

Delavan, WI 53115

P: (262) 728-1900 or (800) 252-5200

E: wcb@spxflow.com

SPX FLOW, Inc. reserves the right to incorporate our latest design and material changes without notice or obligation.

Design features, materials of construction and dimensional data, as described in this bulletin, are provided for your information only and should not be relied upon unless confirmed in writing. Please contact your local sales representative for product availability in your region. For more information visit www.spxflow.com.

The green "y" and "x" are trademarks of SPX FLOW, Inc.

ISSUED 07/2018 DS-1233

COPYRIGHT © 2018 SPX FLOW, Inc.